

**USE
AND
MAINTENANCE
MANUAL**

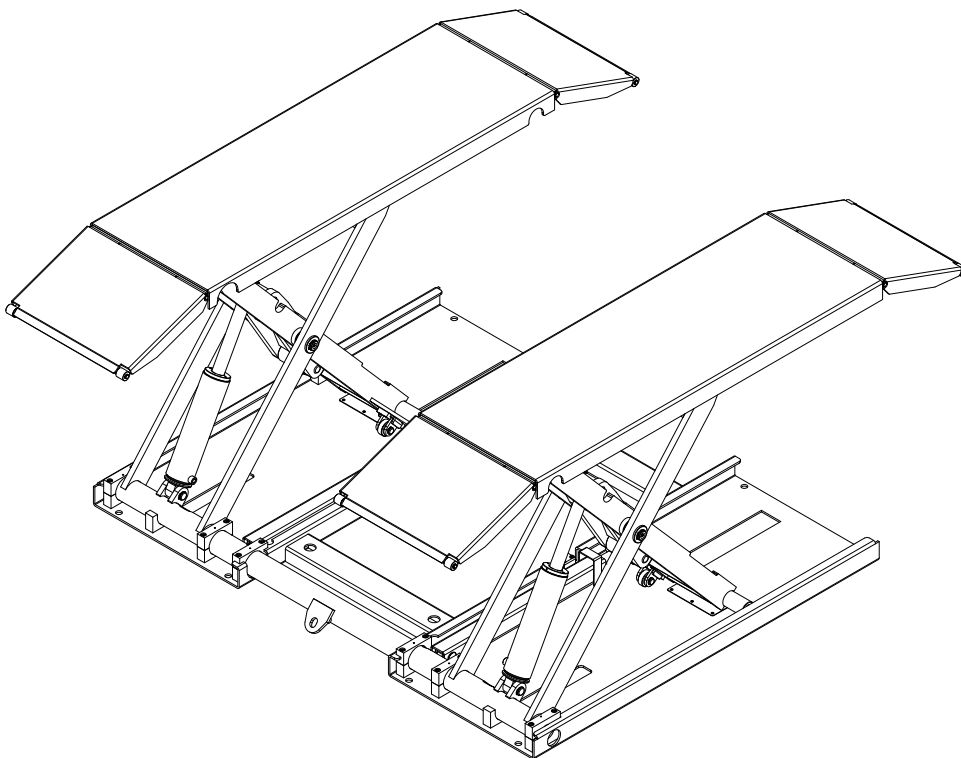



**MID-RISE SCISSOR LIFT
PORTABLE TYPE**

SCT-7530



PRINTING CHARACTERS AND SYMBOLS

Throughout this manual, the following symbols and printing characters are used to facilitate reading:

	Indicates the operations which need proper care
	Indicates prohibition
	Indicates a possibility of danger for the operators
	Indicates the direction of access for motor vehicles to the lift
BOLD TYPE	Important information

	WARNING: before operating the lift and carrying out any adjustment, read carefully chapter 7 “installation” where all proper operations for a better functioning of the lift are shown.
---	--

CONTENTS

1	GENERAL INFORMATION	4
2	PRODUCT IDENTIFICATION	6
3	PACKING, TRANSPORT AND STORAGE	7
4	PRODUCT DESCRIPTION	8
5	TECHNICAL SPECIFICATION	9
6	SAFETY	16
7	INSTALLATION	19
8	OPERATION AND USE	22
9	MAINTENANCE	24
10	TROUBLESHOOTING	25

CHAPTER 1 – GENERAL INFORMATION

This chapter contains warning instructions to operate the lift properly and prevent injury to operators or objects.

This manual has been written to be used by shop technicians in charge of the lift (operator) and routine maintenance technician (maintenance operator).

The operating instructions are considered to be an integral part of the machine and must remain with it for its whole useful life.

Read every section of this manual carefully before operating the lift and unpacking it since it gives helpful information about:

- SAFETY OF PEOPLE
- SAFETY OF THE LIFT
- SAFETY OF LIFTED VEHICLES

The company is not liable for possible problems, damage, accidents, etc. resulting from failure to follow the instructions contained in this manual.

Only skilled technicians of **AUTHORISED DEALERS** or **SERVICE CENTRES AUTHORISED** by the manufacturer shall be allowed to carry out lifting, transport, assembling, installation, adjustment, calibration, settings, extraordinary maintenance, repairs, overhauling and dismantling of the lift.

THE MANUFACTURER IS NOT RESPONSIBLE FOR POSSIBLE DAMAGE TO PEOPLE, VEHICLES OR OBJECTS IF SAID OPERATIONS ARE CARRIED OUT BY UNAUTHORIZED PERSONNEL OR THE LIFT IS IMPROPERLY USED.

Any use of the machine made by operators who are not familiar with the instructions and procedures contained herein shall be forbidden.

1.1 MANUAL KEEPING

For a proper use of this manual, the following is recommended:

- keep the manual near the lift, in an easily accessible place.
- keep the manual in an area protected from the damp.
- use this manual properly without damaging it.
- Any use of the machine made by operators who are not familiar with the instructions and procedures contained herein shall be forbidden.

This manual is an integral part of the lift: it shall be given to the new owner if and when the lift is resold.

1.2 OBLIGATION IN CASE OF MALFUNCTION

	In case of machine malfunction, follow the instructions contained in the following chapters.
---	---

1.3 CAUTIONS FOR THE SAFETY OF THE OPERATOR

Operators must not be under the influence of sedatives, drugs or alcohol when operating the machine.

	Before operating the lift, operators must be familiar with the position and function of all controls, as well as with the machine features shown in the chapter “Operation and use”
---	--

1.4 WARNINGS

	Unauthorized changes and/or modifications to the machine relieve the manufacturer of any liability for possible damages to objects or people. Do not remove or make inoperative the safety devices, this would cause a violation of safety at work laws and regulations.
---	---

	Any other use which differs from that provided for by the manufacturer of the machine is strictly forbidden.
---	---

	The use of non genuine parts may cause damage to people or objects
--	---

DECLARATION OF WARRANTY AND LIMITATION OF LIABILITY

The manufacturer has paid proper attention to the preparation of this manual. However, nothing contained herein modifies or alters, in any way, the terms and conditions of manufacturer agreement by which this lift was acquired, nor increase, in any way, manufacturer’s liability to the customer.

TO THE READER

Every effort has been made to ensure that the information contained in this manual is correct, complete and up-to date. The manufacturer is not liable for any mistakes made when drawing up this manual and reserves the right to make any changes due the development of the product, at any time.

CHAPTER 2 – PRODUCT IDENTIFICATION

The identification data of the machine are shown in the label placed on the control unit.

LOGO	
Type:
Model:
Serial Number:
Year of manufacturing:
Capacity:
Voltage:
Power:

	Use the above data both to order spare parts and when getting in touch with the manufacturer (inquiry). The removal of this label is strictly forbidden.
--	---

Machines may be updated or slightly modified from an aesthetic point of view and, as a consequence, they may present different features from these shown, this without prejudicing what has been described herein.

2.1 WARRANTY CERTIFICATE

The warranty is valid for a period of 12 months starting from the date of the purchase invoice.

The warranty will come immediately to an end when unauthorized modifications to the machine or parts of it are carried out.

The presence of defects in workmanship must be verified by the Manufacturer's personnel in charge.

2.2 TECHNICAL SERVICING

For all servicing and maintenance operations not specified or shown in these instructions, contact your Dealer where the machine has been bought or the Manufacturer's Commercial Department.

Only skilled personnel who are familiar with the lift and this manual shall be allowed to carry out packing, lifting, handling, transport and unpacking operations.

CHAPTER 3 - PACKING, TRANSPORT AND STORAGE

3.1 PACKING

The packing of the lift is delivered in following components:

- N. 1 base units packed in a steel frame, wrapped up in non-scratch material
 - N. 1 portable power unit packed in a plywood box, including N. 4 rubber pads
- (If requested, optional accessories are available to satisfy each customer's requirements).

The average weight of the package is 600kg.

3.2 LIFTING AND HANDLING

When loading/unloading or transporting the equipment to the site, be sure to use suitable loading (e.g. cranes, trucks) and hoisting means. Be sure also to hoist and transport the components securely so that they cannot drop, taking into consideration the package's size, weight and centre of gravity and it's fragile parts.



3.3 STORAGE AND STACKING OF PACKAGES

Packages must be stored in a covered place, out of direct sunlight and in low humidity, at a temperature between -10°C and +40°C.

Stacking is not recommended: the package's narrow base, as well as its considerable weight and size make it difficult and hazardous.

3.4 DELIVERY AND CHECK OF PACKAGES

When the lift is delivered, check for possible damages due to transport and storage; verify that what is specified in the manufacturer's confirmation of order is included. In case of damage in transit, the customer must immediately inform the carrier of the problem.

Packages must be opened paying attention not to cause damage to people (keep a safe distance when opening straps) and parts of the lift (be careful the objects do not drop from the package when opening).

CHAPTER 4 - PRODUCT DESCRIPTION

LIFT DESCRIPTION (Ref. Figure 1)

The surface mounted lift has been designed for the lifting of motor-vehicles for maintenance.

The maximum lifting weight is as specified on the serial plate.

All mechanical frames, such as platforms, extensions, base frames and arms have been built in steel plate to make the frame stiff and strong while keeping a low weight

The electro hydraulic operation is described in detail in chapter 8.

This chapter describes the lift's principal elements, allowing the user to be familiar with the machine. As shown in figure 1, the lift is composed of two platforms (1) each equipped with N.2 ramps (2), placed on the ground by means of two base frames (3).

Platforms are linked to the base frame by means of a scissors lifting system.

The lifting system of each platform is composed of N.2 arms (4) and a cylinder (5).

Motion is transmitted by a lever system, from the cylinders to the lever arm (6).

Lowering and lifting are carried out by operation of the control unit (7) which is placed on a carriage (8).

The mechanical safety operating by a pneumatic cylinder is installed at each base and controlled by the control panel.

The lift is equipped with N.2 bolster beams in front and rear, connected between two base frames to keep the two platforms always leveled during lifting and lowering.

On the portable type, N.2 wheels (9) are installed on the base, by means of carriage the lift is possible to be moved when the lift is lowered completely.

Figure 1 – LIFT

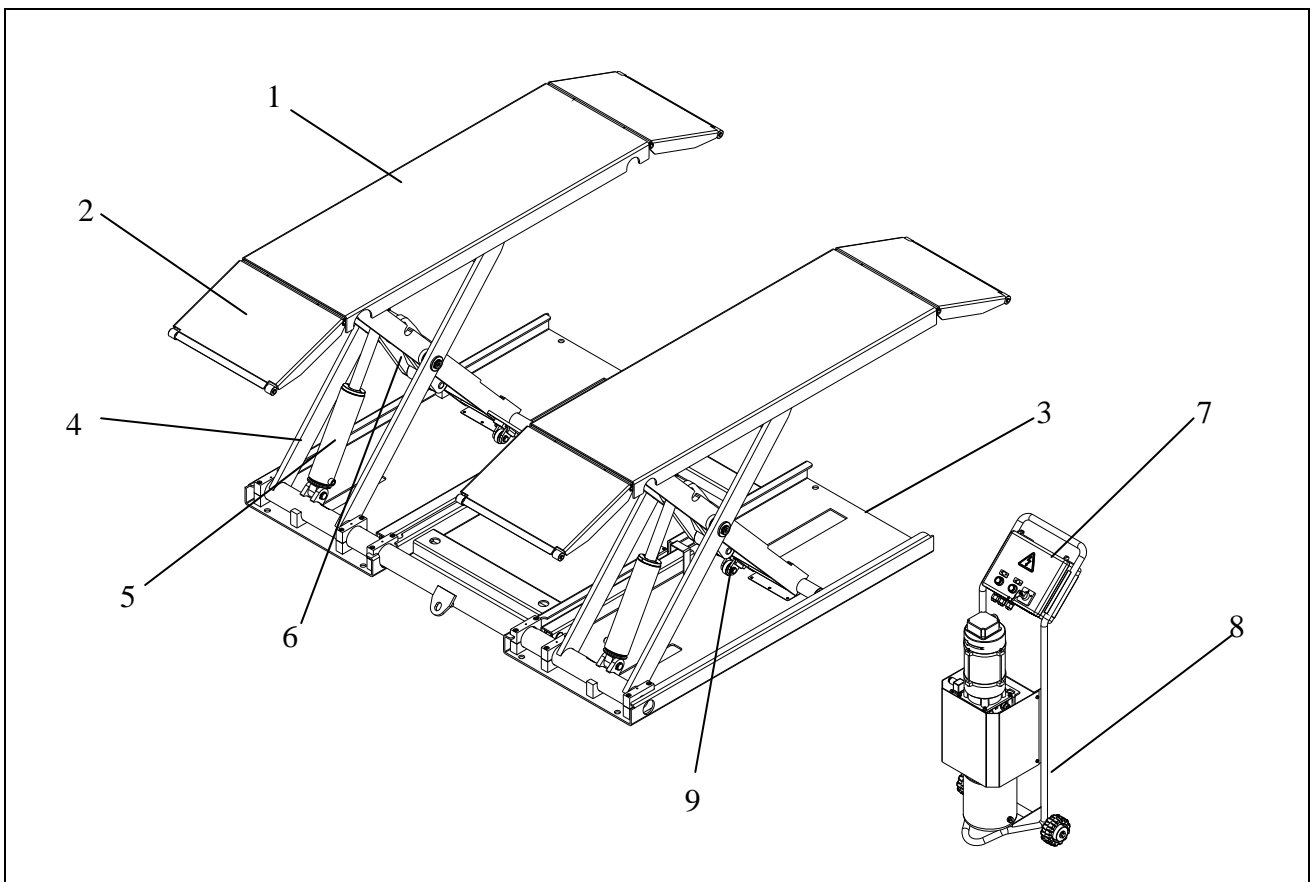

CHAPTER 5 - TECHNICAL SPECIFICATION

5.1 SIZE AND MAIN FEATURES (Ref. Figure 2)

CAPACITY	3000KG
Max. lifting height	1000mm
Min. lift height	105mm
Length of the platform	1420 mm
Width of platform	490mm
Free width between platforms	860mm
Overall length	2158mm
Overall width	1840
Lifting time	35 s
Lowering time	40 s
Compressed air pressure	6 bar – 8 bar
Noise level	80 dB(A)/1m
Working temperature	-10 °C ÷ 40 °C
Average weight of package	600g

5.2 ELECTRIC MOTOR

Type	ML90L4-B14	MS90L4-B14
Voltage	230V/220V-1Ph	400V/380V-3Ph
Power	1.5 KW	1.5 KW
N° Poles	4	4
Speed	1375 rpm	1375 rpm
Motor enclosure type	B14	
Insulation class	IP 54	

Motor connection must be carried out referring to the attached wiring diagrams (the figure. 5).

The motor direction of rotation is shown in the label placed on the motor.

Before use of the lift, make sure to check if the motor specification shown in the nameplate of the motor conforms to the local electric supply.

If there is over 10% fluctuation on the electrical power supply, it is suggested to use the voltage stabilizer to protect the electrical components and system from overloading.

5.3 PUMP

Type	Gear
Flow rate	2.1 cm ³ /g
Continuous working pressure	230 bar – 250 bar

Figure 2 - LAYOUT

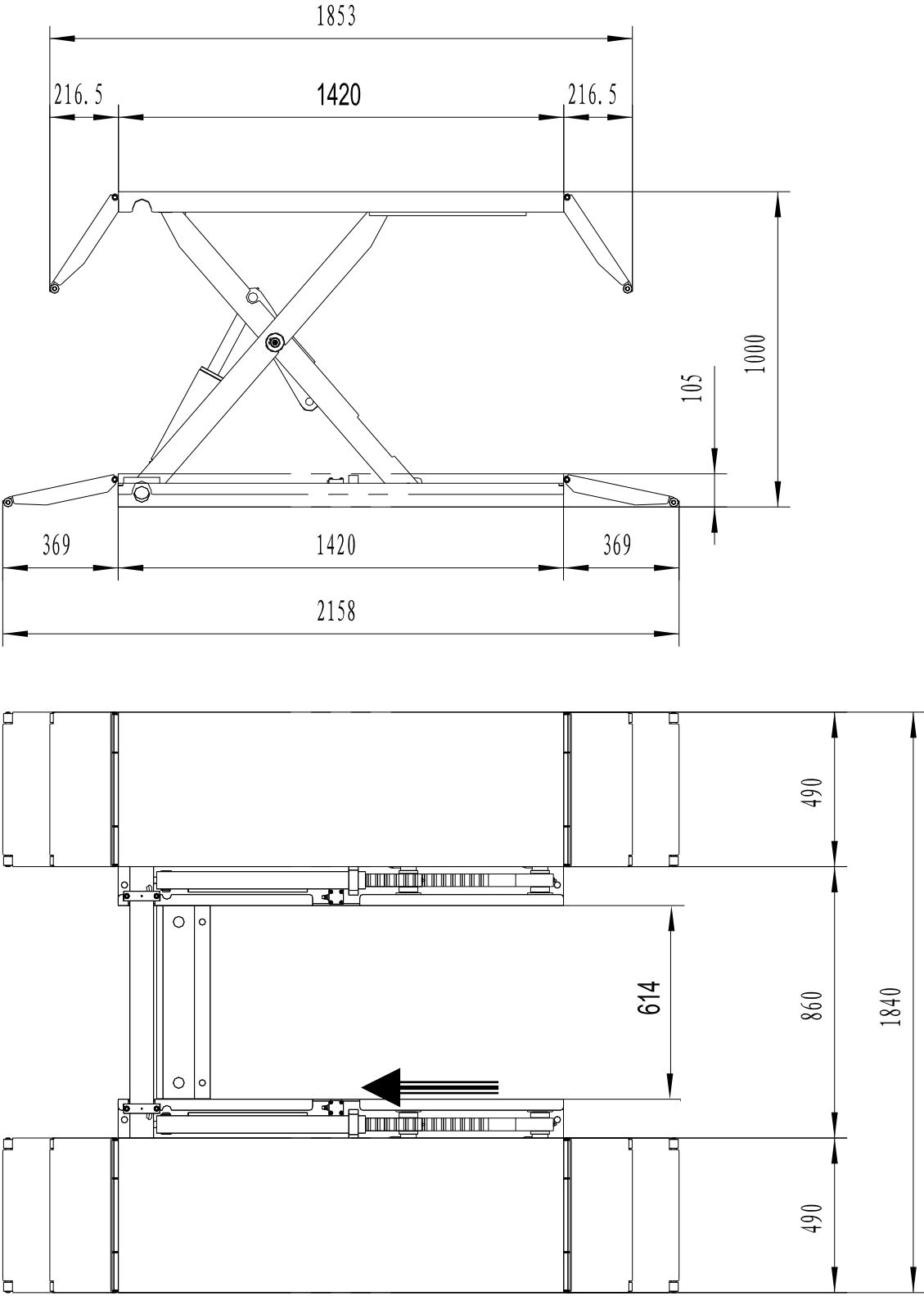

5.4 HYDRUALIC POWER UNIT

FIG. 3 – HYDRAULIC POWER UNIT

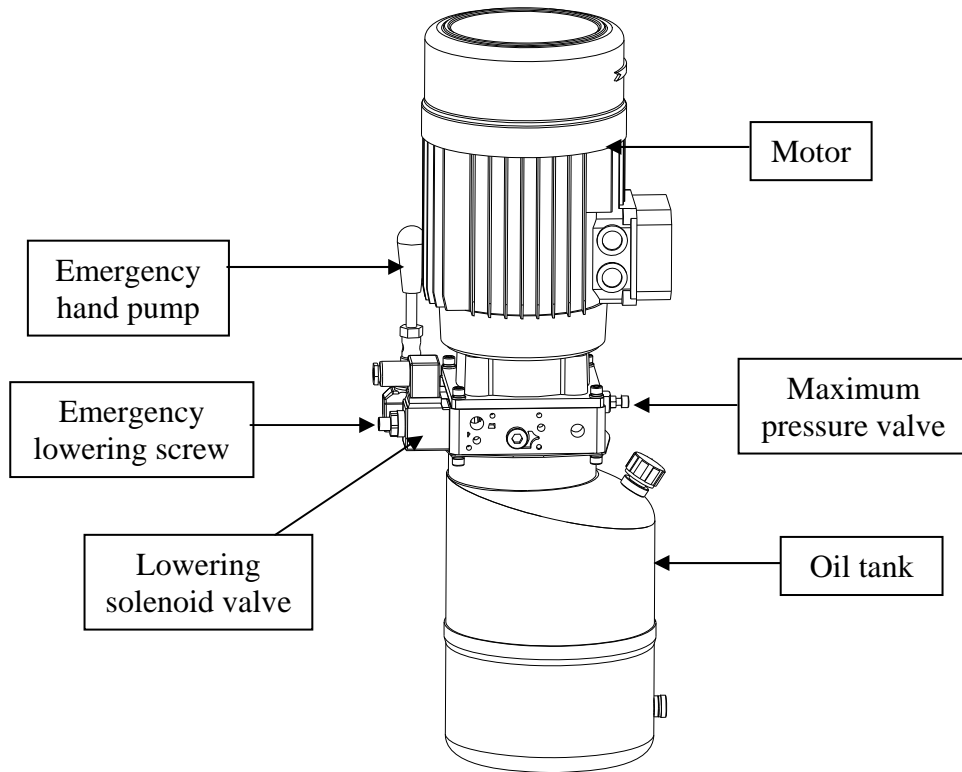

5.5 OIL

Use wear proof oil for hydraulic drive, in conformity with *ISO 6743/4* rules (HM class). The oil with features similar to those shown in the table is recommended.

TEST STANDARDS	FEATURES	VALUE
ASTM D 1298	Density 20°C	0.8 kg/l
ASTM D 445	Viscosity 40°C	32 cSt
ASTM D 445	Viscosity 100°C	5.43 cSt
ASTM D 2270	Viscosity index	104 N°
ASTM D 97	Pour point	~ 30 °C
ASTM D 92	Flash point	215 °C
ASTM D 644	Neutralization number	0.5 mg KOH/g

	CHANGE HYDRAULIC OIL AT 1 YEAR INTERVALS
---	---

Figure 4 – HYDRAULIC PLAN



1	Hydraulic cylinder	6	Lowering solenoid valve
2	Safety valve	7	Gear pump
3	Emergency hand pump	8	Motor
4	Non return valve	9	Oil filter
5	Maximum pressure valve		

Figure 5a – ELECTRICAL WIRING DIAGRAM (380V/400V-3PH)

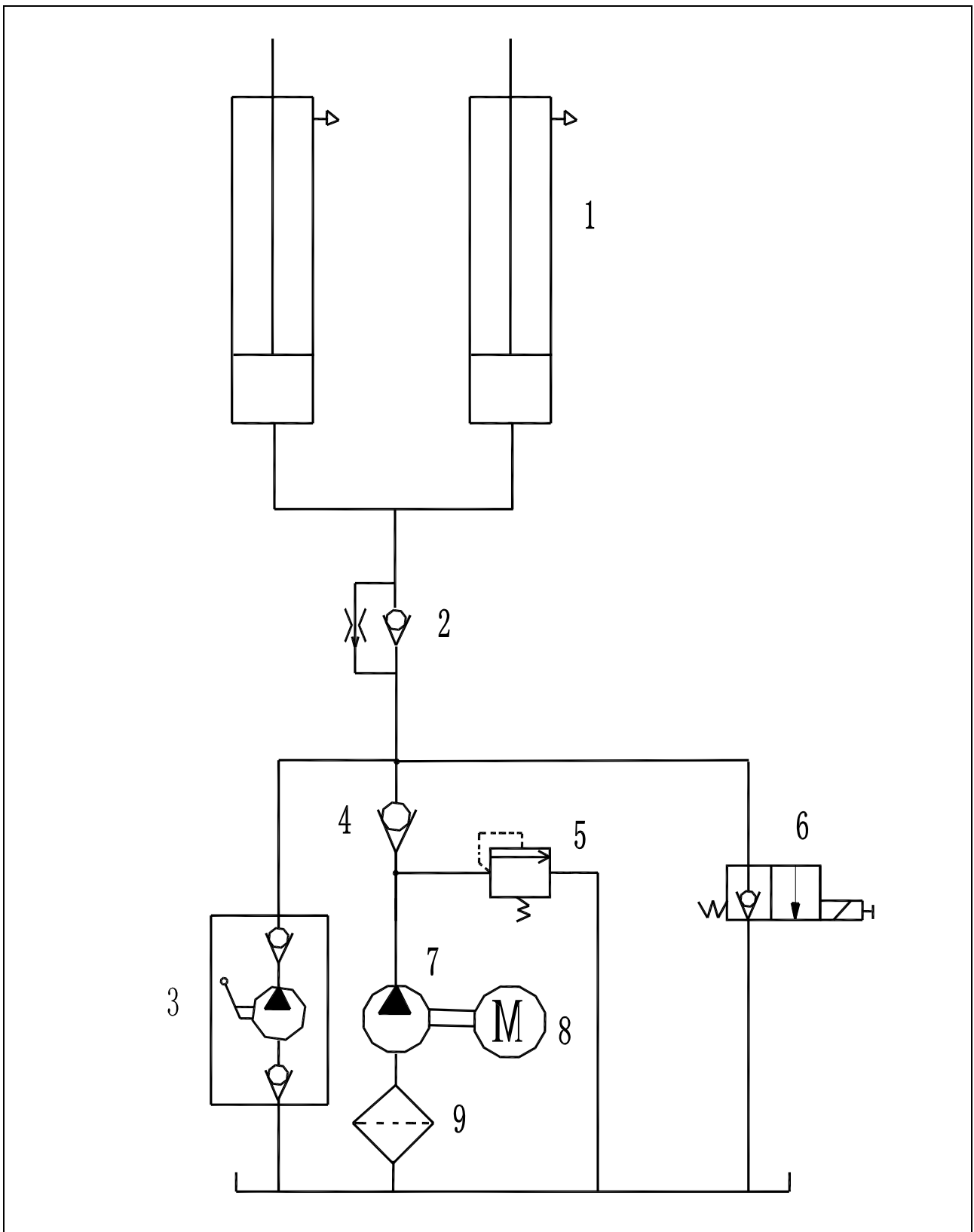
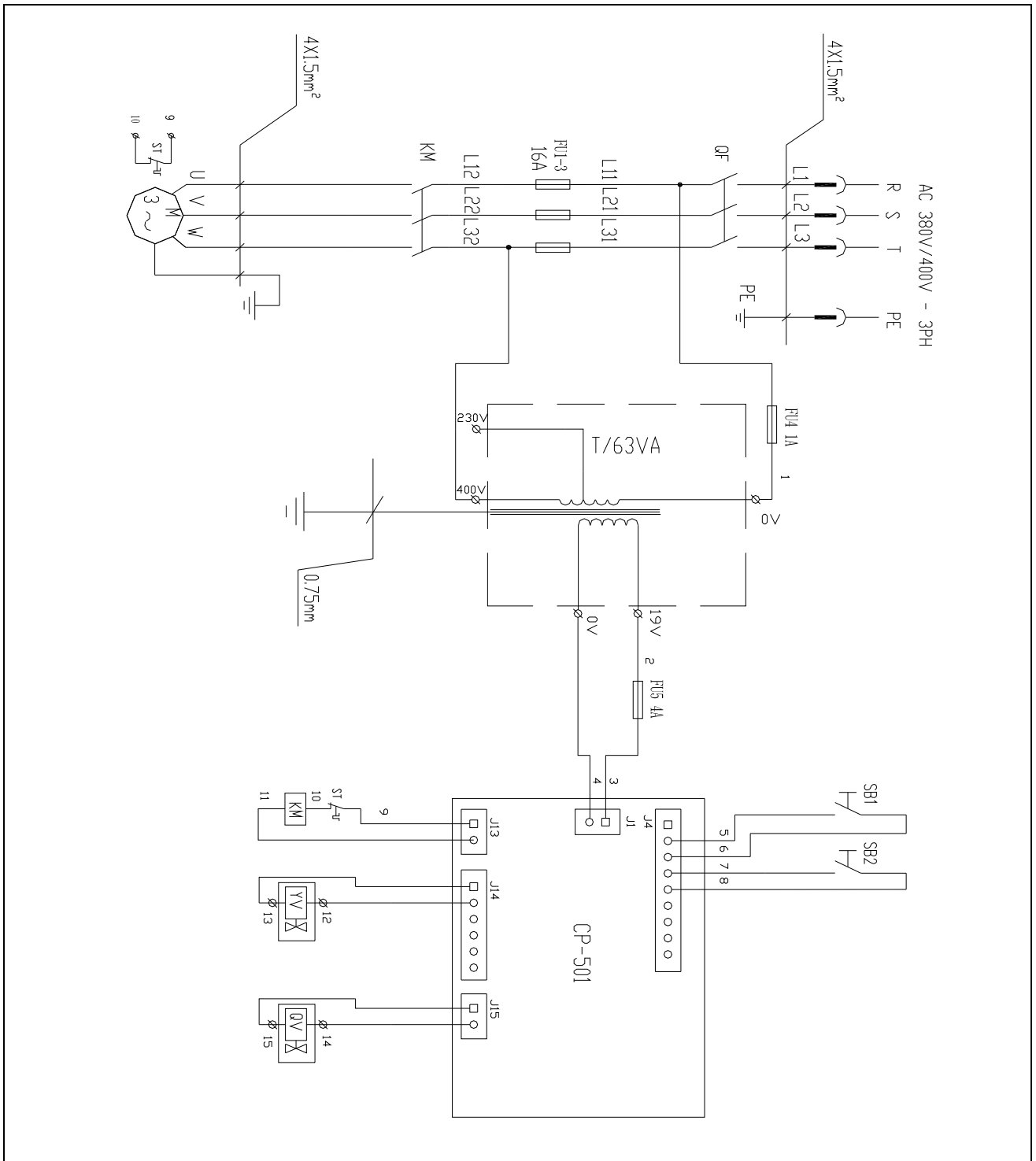

QF	Power switch
M	Motor 1.5KW
T	Transformer 63VA
ST	Overheat protector
SB1	Lifting pushbutton (UP)
SB2	Lowering pushbutton (DOWN)
KM	Contactor DC
YV	Lowering solenoid valve
QV	Solenoid air valve

Figure 5b – ELECTRICAL WIRING DIAGRAM (220V/230V-1PH)

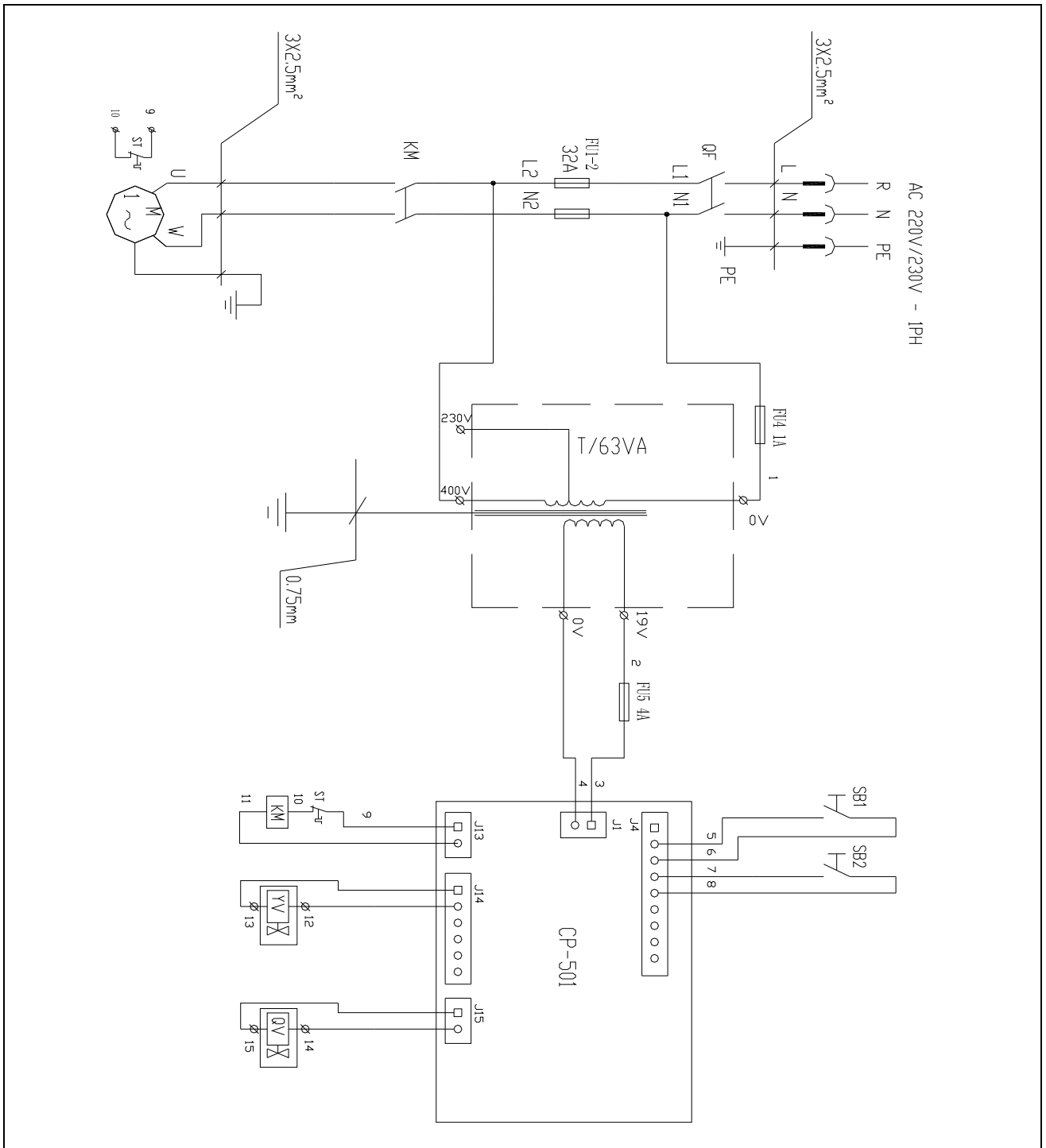

QF	Power switch
M	Motor 1.5KW
T	Transformer 63VA
ST	Overheat protector
SB1	Lifting pushbutton (UP)
SB2	Lowering pushbutton (DOWN)
KM	Contactore DC
YV	Lowering solenoid valve
QV	Solenoid air valve

Figure. 6 – PNEUMATIC PLAN

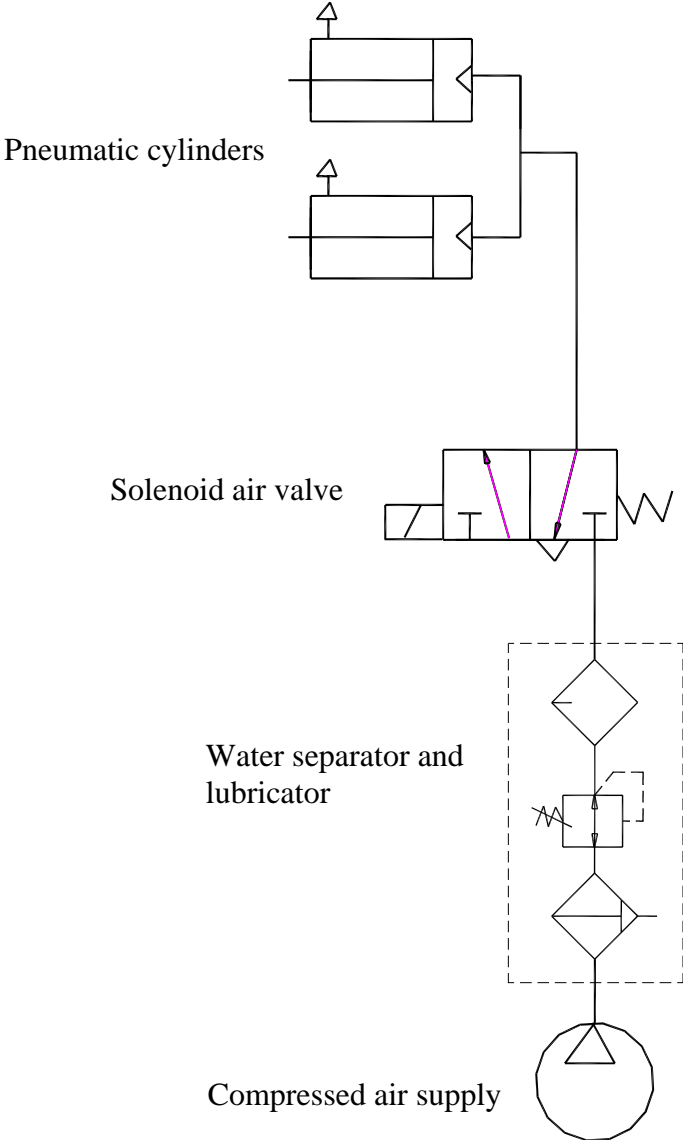

CHAPTER 6 – SAFETY

Read this chapter carefully and completely because it contains important information for the safety of the operator and the person in charge of maintenance.

	<p>The lift has been designed and built for lifting vehicles and making them stand above level in a closed area. Any other use is forbidden.</p> <p>The manufacturer is not liable for possible damages to people, vehicles or objects resulting from an improper or unauthorized use of the lift.</p>
---	--

For operator and people safety, a safety area at least 1m free away from the lift must be vacated during lifting and lowering. The lift must be operated only from the operator's control site in this safety area.

Operator's presence under the vehicle, during working, is only admitted when the vehicle is lifted and platforms are not running.

	<p>Never use the lift when safety devices are off-line. People, the lift and the vehicles lifted can be seriously damaged if these instructions are not followed.</p>
---	--

6.1 GENERAL WARNINGS

The operator and the person in charge of maintenance must follow accident-prevention laws and rules in force in the country where the lift is installed

They also must carry out the following:

- neither remove nor disconnect hydraulic, electric or other safety devices;
- carefully follow the safety indications applied on the machine and included in the manual;
- observe the safety area during lifting;
- be sure the motor of the vehicle is off, the gear engaged and the parking brake put on;
- be sure only authorized vehicles are lifted without exceeding the maximum lifting capacity;
- Verify that no one is on the platforms during lifting or standing.

6.2 RISKS DURING VEHICLE LIFTING

To avoid overloading and possible breaking, the following safety devices have been used:

- a maximum pressure valve placed inside the hydraulic unit to prevent excessive weight.
- a special design of the hydraulic system, in case of pipeline failure, to prevent sudden lift lowering..

	<p>The maximum pressure valve has been preset by the manufacturer to a proper pressure. DO NOT try to adjust it to overrun the rated lifting capacity.</p>
---	---

6.3 RISKS FOR PEOPLE

All risks the personnel could run, due to an improper use of the lift, are described in this section.

6.4 PERSONNEL CRUSHING RISKS

During lowering of runways and vehicles, personnel must not be within the area covered by the lowering trajectory. The operator must be sure no one is in danger before operating the lift.



Fig. 7a



Fig. 7b

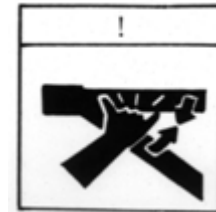

Fig. 7c

6.5 BUMPING RISK

When the lift is stopped at relatively low height for working, the risk of bumping against projecting parts occurs.



Fig. 8

6.6 RISK OF THE VEHICLE FALLING FROM THE LIFT

Vehicle falling from the lift can be caused when the vehicle is improperly placed on platforms, and when its dimensions are incompatible with the lift or by excessive movement of the vehicle. In this case, keep immediately away from the working area.



Fig. 9a



Fig. 9b



Fig. 9c

6.7 SLIPPING RISKS

The risk of slipping can be caused by oil or dirt on the floor near the lift.



Fig. 10



Keep the area under and around the lift clean. Remove all oil spills.

6.8 ELECTROCUTION RISKS

Avoid use of water, steam, and solvent, varnish jets in the lift area where electric cables are placed and, in particular, next to the electric panel.

6.9 RISKS RESULTING FROM IMPROPER LIGHTING

Make sure all areas next to the lift are well and uniformly lit, according to local regulations.

6.10 RISKS OF BREAKING COMPONENT DURING OPERATION

Materials and procedures, suitable for the designed parameters of the lift, have been used by the manufacturer to build a safe and reliable product. Operate the lift only for the use it has been designed for and follow the maintenance schedule shown in the chapter “Maintenance”.



Fig. 11

6.11 RISKS FOR UNAUTHORIZED USES

The presence of unauthorized persons next to the lift and on the platforms is strictly forbidden during lifting as well as when the vehicle has been already lifted



Fig. 12



Any use of the lift other than that herein specified can cause serious accidents to people in close proximity of the machine.

CHAPTER 7 – INSTALLATION



Only skilled technicians, appointed by the manufacturer, or by authorized dealers, must be allowed to carry out installation. Serious damage to people and to the lift can be caused if installations are made by unskilled personnel.

7.1 CHECKING FOR PLACE SUITABILITY

The lift has been designed to be used in covered and sheltered places free of overhead obstructions. The working place must not be next to washing areas, painting workbenches, solvent or varnish deposits. The relevant standards of the local Health and Safety at Work regulations, for instance, with respect to minimum distance to wall or other equipment, escapes and the like, must be observed.

All areas next to the lift must be well and uniformly lit.

7.2 CONCRETE SURFACE

The lift must be placed on the concrete surface sufficiently resistant. The surface must be suitable for bearing maximum stress values, also in unfavorable working conditions. The surface must be perfectly leveled.

7.3 HYDRAULIC SYSTEM CONNECTION

- Connect hydraulic hoses referring to Fig. 13;
- Tighten fittings thoroughly.

Figure 13 – HYDRAULIC CONNECTIONS

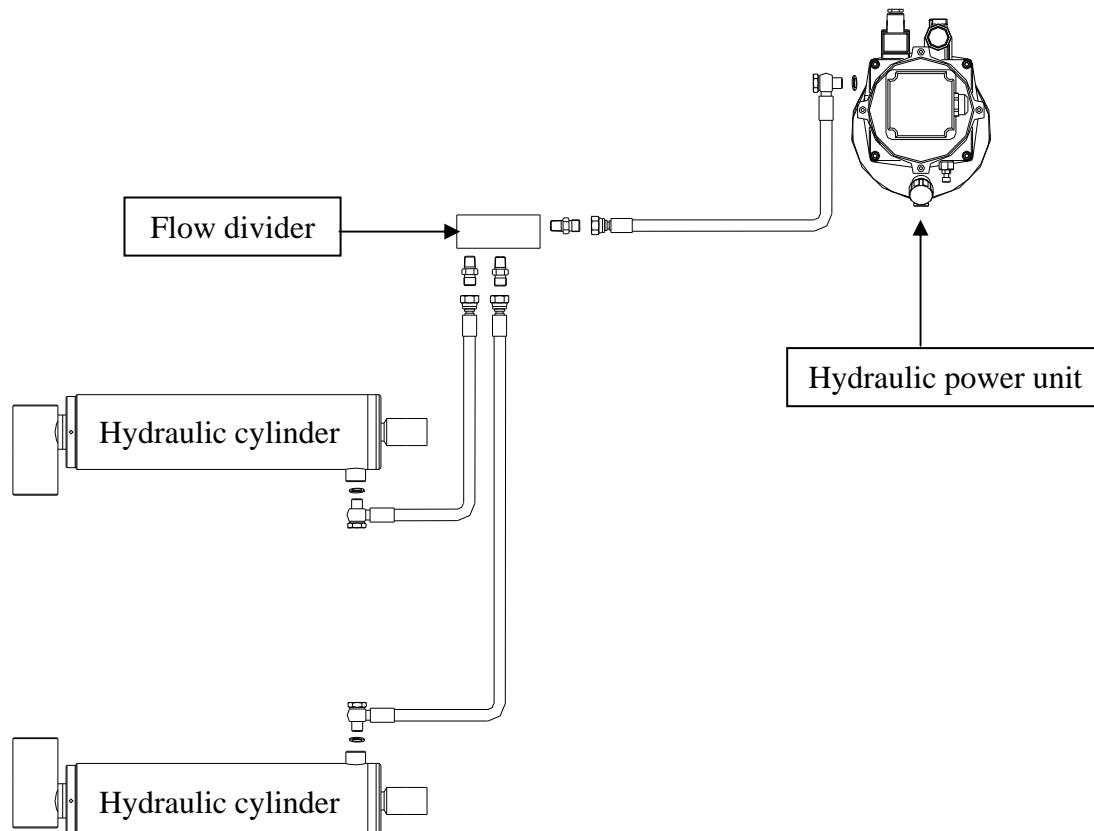

7.4 MAKE THE ELECTRICAL HOOKUP TO HYDRAULIC POWER UNIT

	<p>The hookup work must be carried out by a qualified electrician.</p> <p>Make sure that the power supply is right.</p> <p>Make sure the connection of the phases is right. Improper electrical hook-up can damage motor and will not be covered under warranty.</p> <p>DO NOT run the hydraulic unit with no oil. Damage to pump can occur.</p> <p>The power unit must be kept dry.</p>
---	---

- Make the electric hookup to the power unit referring to the attached the electric diagram figure 5 using the included electric cable.
- Make sure the connection of the phases is right and lift is grounded.

7.5 PNEUMATIC SYSTEM CONNECTION

	<p>When routing the pneumatic line, make sure that the line is clear of any moving part. Failure to do so may result in safety lock failure which may result in damage or personal harm.</p>
---	---

The pneumatic supply at site (to which the pneumatic system of the lift is connected) must be equipped with a servicing unit composed of water separator, lubricator and pressure reducer. These devices can be supplied by the manufacturer on request.

For the connection of the pneumatic lines proceed as follow:

- Connect the pneumatic lines pre-assembled on the lift to the solenoid air valve in the control unit according to the pneumatic plan (fig. 6);
- Connect the pneumatic system of the lift to the pneumatic supply at site;
- Check the pneumatic control operations for proper performance.

7.6 START

- Make sure all pins and bolts to insure proper mounting
- Make sure the electrical system feeding voltage is equal to that specified in the nameplate on the motor
- Make sure the electric connections are in compliant with diagrams Fig. 5
- Make sure no leakage or blow-up in hydraulic line
- Make sure the working area is free from people and objects
- Grease sliding seats of blocks placed under platforms and on bases
- Pour oil in the tank (*about 5 liters more than one time*)
- Verify that the control unit is powered
- Verify that the motor direction of rotation is that shown on the label by pushing the lifting button. **IF MOTOR GETS HOT OR SOUNDS PECULIAR, STOP IMMEDIATELY AND RECHECK THE ELECTRIC CONNECTIONS**

7.6 BLEEDING



During this procedure, DO NOT attempt to raise the lift with any load.

- Raising the lift slowly by pressing the lifting button until cylinders bottom out and the lift stops. DO NOT continue pressing button after lift reaches full height. Damage to motor can occur if continued.
- Cylinders may jump upon initial start up which is normal due to trapped air inside the hydraulic lines. In case that the lift can not be raised upon initial start up due to trapped air inside the pump: unloose the maximum pressure valve, in-push the lifting button and retighten the valve after trapped air has escaped, then raise the lift at full height.
- Lower the lift completely by pressing the lowering button.
- Repeat raise and lower the lift completely at least 3 times to equalize the oil pressure in each cylinder.

7.7 CHECKS LESS LOAD



During this procedure, observe all operating components and check for proper installation and adjustment. DO NOT attempt to raise vehicle until a thorough operation check has been completed.

Carry out two or three complete cycles of lowering and lifting and check:

- the safety devices for proper operation
- proper oil level in the tank
- no leakage and blow-by in hydraulic line and pneumatic line
- cylinder for proper operation
- the lift for reaching its maximum height

7.8 CHECKING WITH LOAD



WARNING: The lift must be raised at least 300mm out of the ground before taking the load.



It is extremely forbidden to load the vehicle when the lift wheels are on the lift. Failure to do so can damage the lift severely.

Carry out two or three complete cycles of lowering and lifting and check:

- Repeat the 7.7 section
- Check no strange noise during lifting and lowering

CHAPTER 8 - OPERATION AND USE

	<p>Never operate the lift with any person or equipment below.</p> <p>Never exceed the rate lifting capacity.</p> <p>Always ensure that the lift safety is locked before any attempt is made to work on or near the vehicle.</p> <p>Do not permit the electric control unit to get wet!</p>
---	--

8.1 CONTROLS

CONTROL PANEL (Figure 14)

POWER SWITCH (1)

The switch can be set in two positions:

- **0 position:** the lift electric circuit is not powered; the switch can be padlocked to prevent the use of the lift.
- **1 position:** the main electric circuit is powered

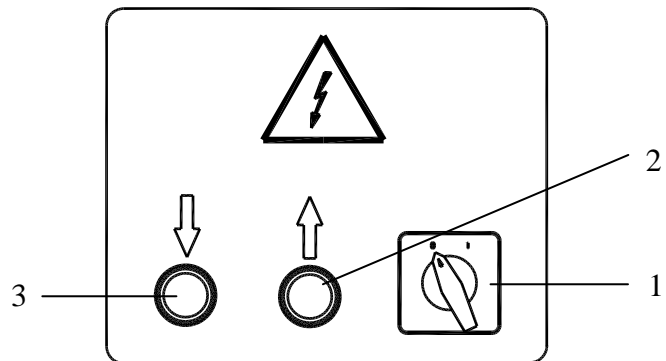

Fig. 14

LIFTING BUTTON (2)

- When pressed, the electric circuit for the lift operates the motor and hydraulic circuit to raise the lift

LOWERING BUTTON (3)

- When pressed, the lift starts to release the safety, and in the meantime the lift begins to descend under its weight and the load lifted

8.2 TO MOVE THE LIFT

When the lift needs to be moved, proceed as below:

- Place the lift at a proper height;
- Refer to the figure 15, slide 2 kit of lift wheels onto the support;
- Lower the lift completely by pressing the lifting button. In this case, the rear side of the base will be raised a little bit;
- Attach the hook placed on the carriage to the hole placed on the front beam as shown in the figure 16.
- Pull the carriage to move the lift.

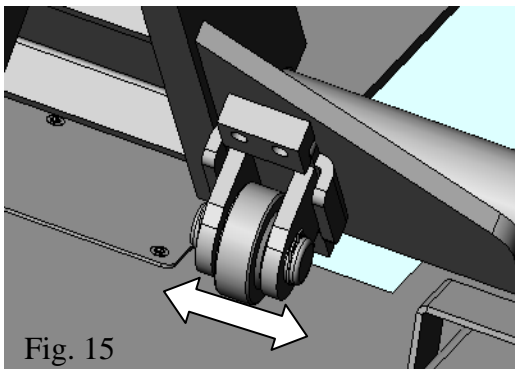

Fig. 15

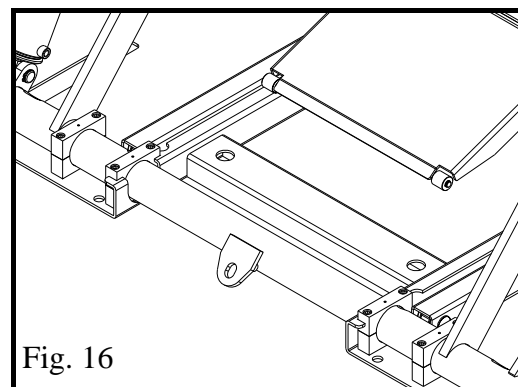

Fig. 16

8.3 TO RAISE THE LIFT



It is extremely forbidden to load the vehicle when the mobile wheels are on the lift. Failure to do so can damage the lift severely.



WARNING: The lift must be raised at least 300mm out of the ground before taking the load.

- Position the vehicle at the centre of the platform. Check to make sure that the vehicle is secured.
- Place the pads in the positions
- Set the power switch to 1 position
- Press the lifting button to raise the vehicle
- To rest the lift in standing position at the desired height by releasing the lifting button.
- Always ensure that the lift rests on the safety before any attempt is made to work on or near the vehicle.

8.4 TO LOWER THE LIFT

- Be sure the safety area is free of people and objects;
- Raise the lift a little bit by pushing the lifting button to clear off the safety;
- Press the lowering button;
- Lower the lift completely.

8.5 MANUAL EMERGENCY LOWERING

In case of no electric power or power unit failure, lower the loaded vehicle manually to its initial position as follows referring to the figure 16 and the figure 17:

- Padlock the power switch;
- If the safety is engaged, the safety should be released before lowering the lift, operate the emergency hand pump (fig.16 - 1) to raise the lift a little bit to clear off the safety;
- Keep pressing EMERGENCY BUTTON (fig.17 - 1) on the solenoid air valve in the control unit;

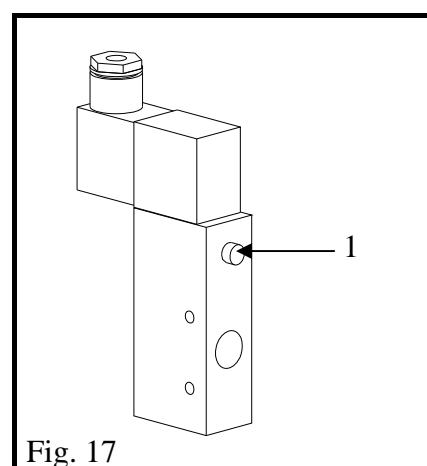
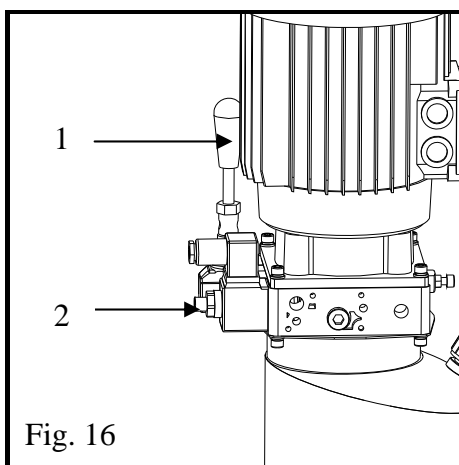

- Unloosen the lowering solenoid valve by turning the emergency screw (fig.16 - 2) anti-clockwise to lower the lift. Screwing or loosing the screw can reduce or increase the lowering speed;
- Retighten the emergency screw by turning clockwise after lowering the lift completely.

CHAPTER 9 - MAINTENANCE

	Only trained personnel who knows how the lift works, must be allowed to service the lift.
---	--

To service properly the lift, the following has to be carried out:

- use only genuine spare parts as well as equipment suitable for the work required;
- follow the scheduled maintenance and check periods shown in the manual;
- discover the reason for possible failures such as too much noise, overheating, oil blow-by, etc.

Refer to documents supplied by the dealer to carry out maintenance:

- functional drawing of the electric and hydraulic equipment
- exploded views with all data necessary for spare parts ordering
- list of possible faults and relevant solutions.

	Before carrying out any maintenance or repair on the lift, disconnect the power supply, padlock the general switch and keep the key in a safe place to prevent unauthorized persons from switching on or operating the lift.
---	---

9.1 ORDINARY MAINTENANCE

The lift has to be properly cleaned at least once a month using self-cleaning clothes. Lubricate all pivot pins at least once a week.

	The use of water or inflammable liquid is strictly forbidden.
---	--

Be sure the rod of the hydraulic cylinders is always clean and not damaged since this may result in leakage from seals and, as a consequence, in possible malfunctions.

9.2 PERIODIC MAINTENANCE

Every 3 months	Hydraulic circuit	<ul style="list-style-type: none"> ▪ check oil tank level; refill with oil, if needed; ▪ check the circuit for oil leakage. ▪ check seals for proper conditions and replace them, if necessary;
	Foundation bolts	<ul style="list-style-type: none"> ▪ check bolts for proper tightening
	Hydraulic pump	<ul style="list-style-type: none"> ▪ verify that no noise changes take place in the pump when running and check fixing bolts for proper tightening
	Safety system	<ul style="list-style-type: none"> ▪ check safety devices for proper operation
Every 6 months	Oil	<ul style="list-style-type: none"> ▪ check oil for contamination or ageing. Contaminated oil is the main reason for failure of valves and shorter life of gears pumps
Every 12 months	General check	<ul style="list-style-type: none"> ▪ verify that all components and mechanisms are not damaged
	Electrical system	<ul style="list-style-type: none"> ▪ a check of the electrical system to verify that motor, limit switch and control panel operate properly must be carried out by skilled electricians
	Oil	<ul style="list-style-type: none"> ▪ empty the oil tank and change the hydraulic oil

CHAPTER 10 – TROUBLESHOOTING

A list of possible troubles and solutions is given below

TROUBLE:	POSSIBLE CAUSE:	SOLUTION:
	The main switch is not turned on	Turn the switch on
The lift does not work	There is no power	Check Power on to restore if necessary
	The electrical wires are disconnected	Reconnect
	Fuses are blown	Replace
	The maximum height limit switch is faulty.	Check the switch and relevant connection for proper operation. Replace, if needed.
The lift does not raise	The motor direction of rotation is not correct.	Interchange the two phases on the main switch
	The oil in the hydraulic unit is not sufficient.	Add some hydraulic oil
	Presences of air in the hydraulic circuit	Bleed the hydraulic system
	The UP button is faulty.	Check UP button and connection for proper operation. Replace, if needed
	The maximum pressure valve is faulty	Check and clean if dirty or replace if needed
	The lowering solenoid valve does not open.	Check and clean if dirty or replace if faulty
	The emergency screw of lowering solenoid valve does not close	Retighten the screw
	The pump filter is dirty.	Check and clean if needed.
The pump suction is blown	Check the seal and replace if needed	
The platforms are not leveled	Oil leakages in hydraulic circuit	Check the circuit for any leakage
The lift does not lower when the DOWN button is pressed	The lowering solenoid valve does not work properly	Verify if it is powered and check magneto for damage (replace if disconnected or blown).
	The DOWN button is faulty	Check and replace if needed
	The pressure of compressed air is not sufficient to clear of the safety lock	Adjust air pressure
The lift does not lift or lower smoothly	Leakages or presences of air into hydraulic circuit	Bleed the hydraulic system
	The pump filter is dirty.	Check and clean if needed.
	The pump suction is blown	Check the seal and replace if needed